

THE TRIMLINE CANOPY 10 x 20

Instructions for assembly

We have made these instructions very detailed to introduce you to the TrimLine. After a few set-ups these instructions should no longer be needed.

Please, Assemble the TrimLine at home the first time, not at a show.

The Ball Bungees are stretch cable loops with plastic balls that may be used to bundle the poles into easy to manage bundles.(6 poles per bundle) Check out our **Pole Bags** in our catalog.

The Spikes and Tie-down Screws are intended for use on grass or dirt. On concrete you must use weight (see our **GreatWeights** in our catalog).

Here's a drawing of the complete TrimLine frame with all poles and joints identified by color code and shape.

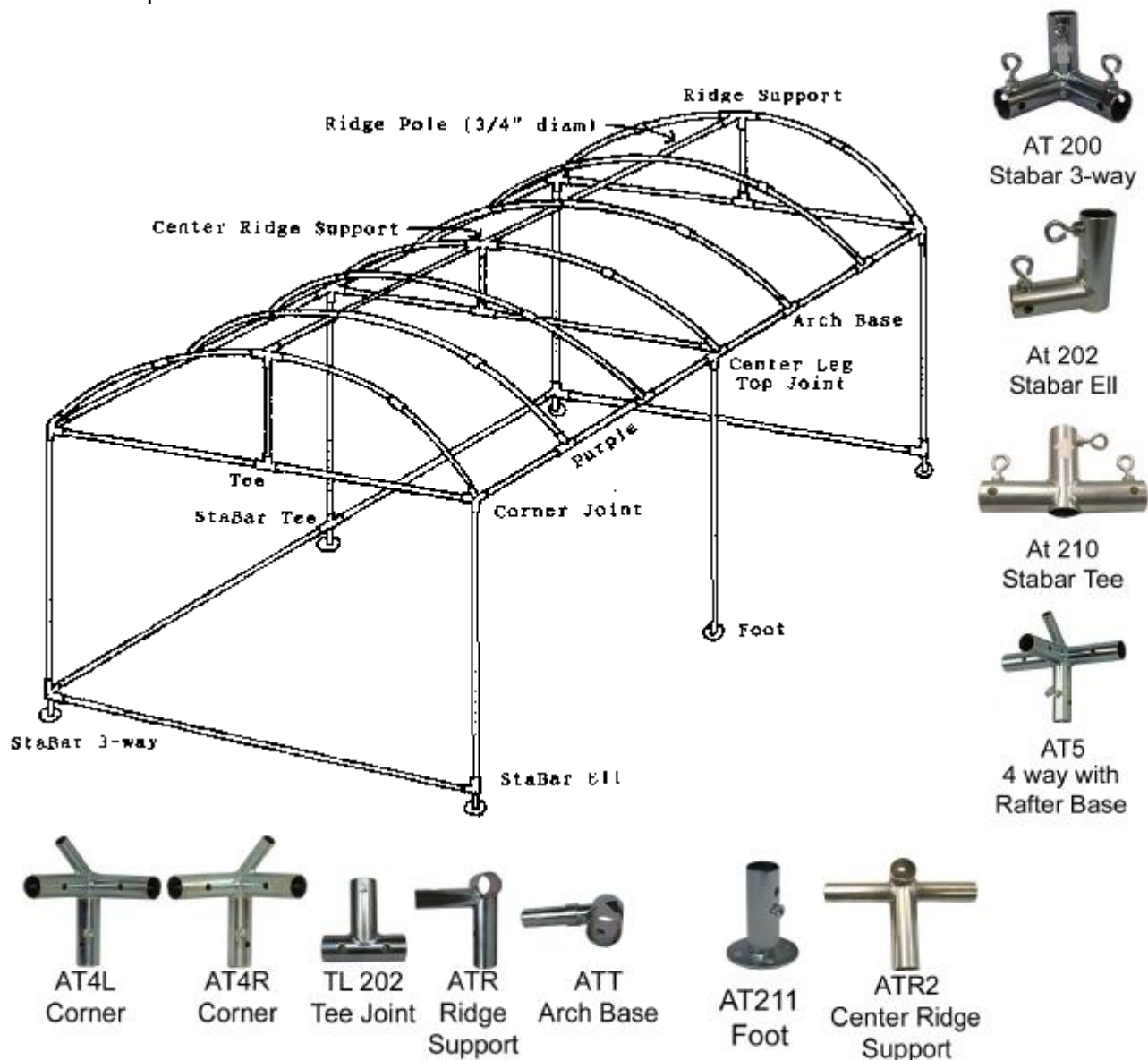

JOIN POLE SECTIONS:

Join sections of poles (male and female) by color - purple pole to purple pole, no-color pole to no-color pole. (Black-coded poles are Leg Sections - see assembly instructions p. 5)



ASSEMBLE ROOF FRAME:

1. Lay out poles and joints as shown in the diagram at the bottom of this page – but don't connect them yet.

2. Slide 2 Arch Base Joints onto each of the Purple-coded poles so that the stubs face to the inside of the canopy - the Black Arrows point to the inside. Attach them to the snap-buttons and attach the corner joints as shown below. The thumbscrews on rear corner joints are on the vertical part of the joint - they receive the leads.

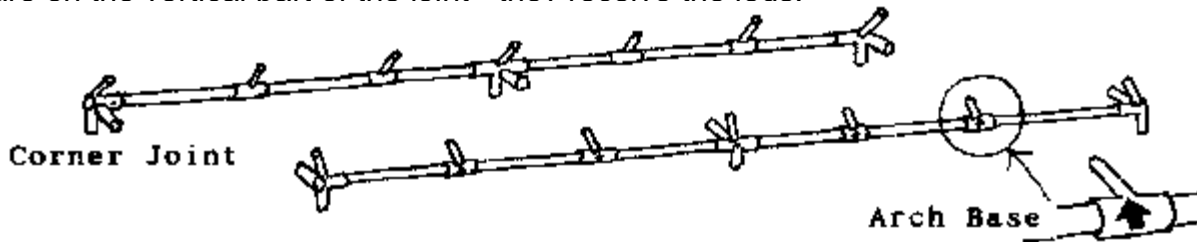

3. Slide Tee Joints onto the three No Color poles. Position each tee joint so that the snap button on the No Color pole snaps onto a hole on the tee joint. This holds the Tee joint in the correct position.

Important: Verify that the Tee Joint is positioned on the exact center of the No Color pole. The Tee Joint is correctly positioned when the place where the two pole sections meet in the middle of the pole is completely covered.

4. Assemble metal poles as per diagram below.

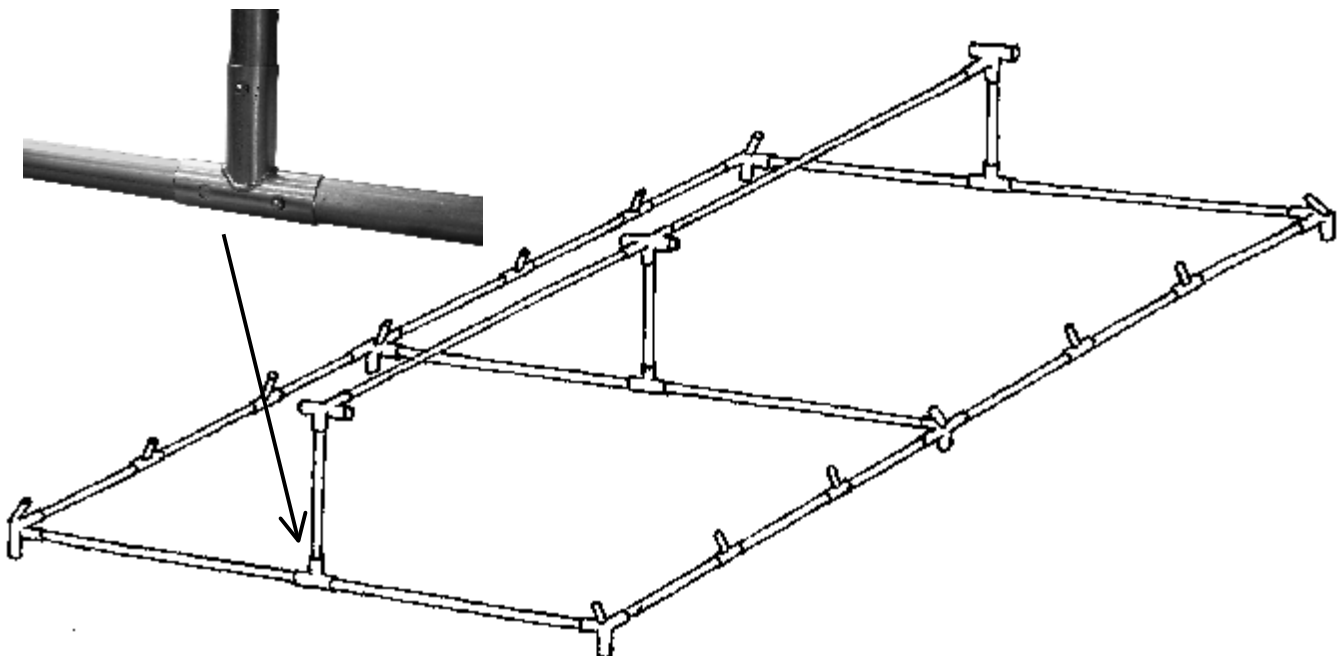

5. Slide plastic pole sections that have a connector on one end onto the Arch Base Joints and the Corner Joints as shown below.

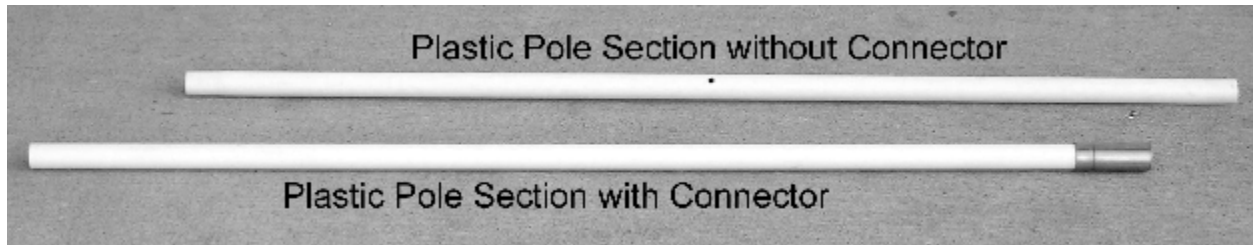

6. Bolt 6 of plastic pole sections that do not have connectors to the Ridge Pole (3/4" diameter) with bolts and wing nuts provided. The plastic pole goes on top of the ridge pole. Slide the other 3 through the Ridge Supports.

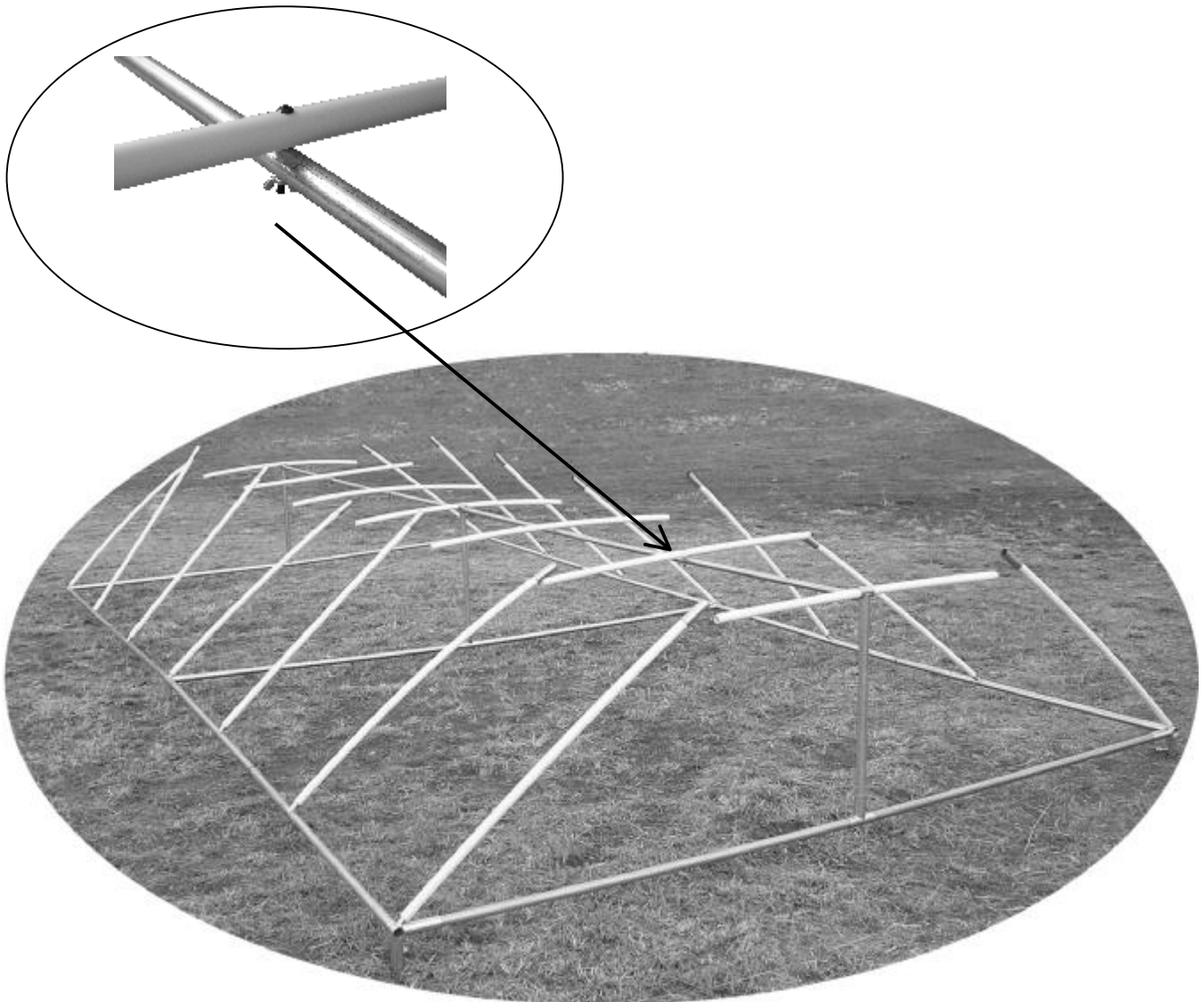



7. Now connect all of the plastic pole sections. To do this, simply push each plastic end down onto each metal connector until each pops into position.

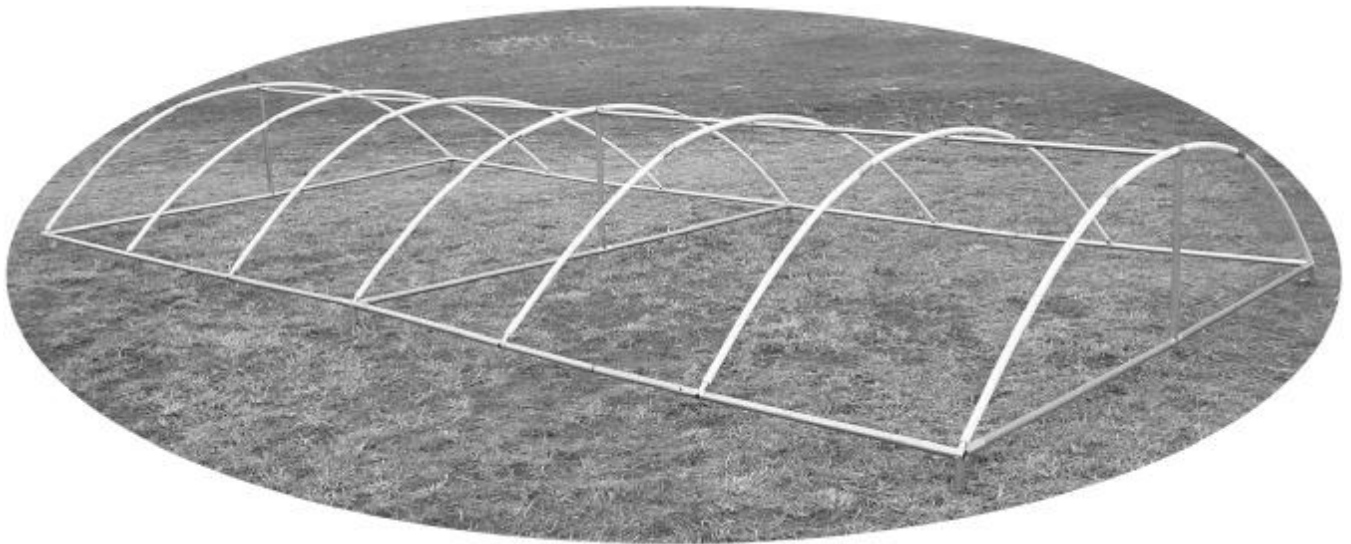

Using Your Telescoping Legs

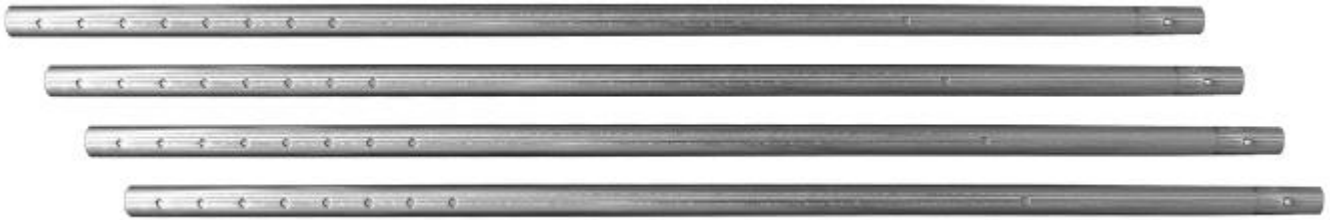

Your telescoping legs will arrive to you in the “collapsed” position with the inner “bottom” section completely inside the outer “top” section – see photo above.

To begin, grasp the top section firmly and shake downwards to slide the bottom section out slightly.

1. Note that there is a hole near the top of the outer section well above the long row of holes. Pull the inner section out about 6 inches and rotate until the snap button at the top of the inner section finds that hole and clicks into place.
2. If you are using your legs for a TrimLine canopy or a Mesh Panel Booth Frame you may slide your StaBar Ell or StaBar 3 way fittings onto the leg bottom before attaching the foot.
3. Slide a foot onto each leg and rotate until the snap button in the leg clicks into the snap button hole in the foot.
4. The telescoping leg is designed so that in the “collapsed” position you may keep the foot and/or the StaBar fittings on the leg when transporting them.
5. To extend the leg for use it's handy to use your toe to hold the foot plate down while lifting the outer section. Lift up until a snap button pops out from the inner section.
6. You may then rest the upper section on this snap button while you rotate the inner section until another snap button clicks into the topmost hole in the long row of holes. This is the extended position. From there you may simply extend the leg one hole at a time to reach the desired height or to account for uneven terrain in outdoor uses.
7. To collapse the leg simultaneously push in the “rest” snap button and the snap button in the long row of holes, and slightly rotate the inner section so the snap button does not catch in each hole on the way down.

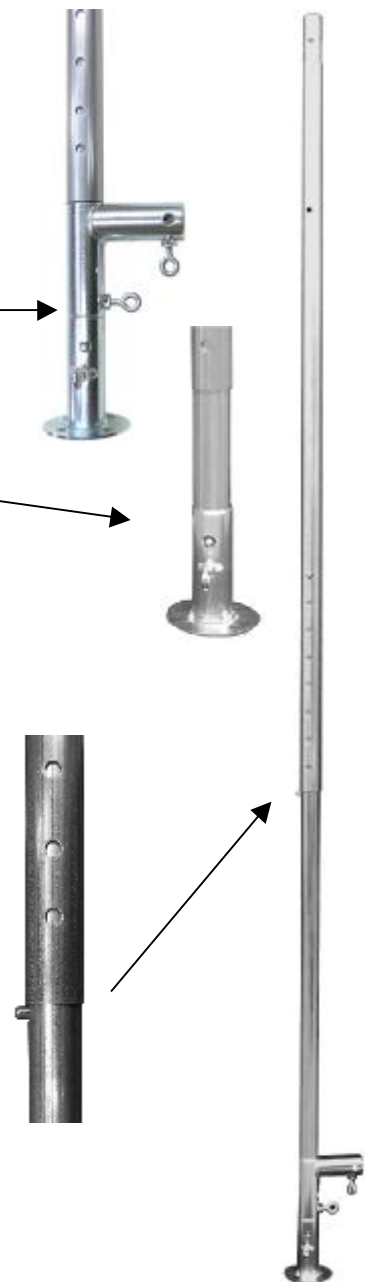

8. Your topper has been folded for shipment in a way that makes set up easier. When you re-fold at the end of a show, follow the instructions on the last page (step 22).
9. Unroll the roof along the top of the arches. Unfold so that topper covers entire roof (See p. 4). Secure with buckled straps – 2 on each side. These attachments are temporary. You will have an opportunity to adjust them and fasten all straps during step 12, below.

NOTE: Using the Easy Riser setup option simplifies this next step.

10. Standing at the side of the canopy, lift the front of the roof and insert the three front legs. (When using StaBar Kit, the two outer legs are the ones with EII Joints attached to the bottom pole sections.)
11. With only the front legs attached, step inside the canopy and secure the roof with the buckles and straps on all four sides. There are also velcro straps at the inside of each corner of the roof. Secure them to the joint at each location.



IMPORTANT

**** DO NOT PULL STRAPS TIGHT *****

These straps are **NOT** intended to pull the roof taut. Their function is to keep the roof on the frame in a wind. Over tightening **will** tear the fabric.

PULLING STRAPS TIGHT MAY RESULT IN DAMAGE TO THE UNIT.

Vents - Although the two vents in the roof ends can be opened and closed from inside the canopy, this is a convenient time (with the canopy on its front legs only) to open or close them depending on the weather outlook. To Open Vents from Inside the Canopy: The bottom edge of the Vent is secured with velcro. Simply separate and reach through to secure vent closure.

Move to the rear, lift, and insert the rear legs. If you are working alone, or if you are not tall enough to conveniently reach the corner joints to insert the rear legs, insert only the top Pole Sections with their Adjuster Sleeves attached, then add the bottom.

Insert StaBar Poles into rear leg StaBar Joints. Then insert poles in front leg Joints. StaBar Joints slide up to allow the poles to remain level, even when individual legs are extended to accommodate uneven terrain. Tighten thumbscrews.

Check that all thumbscrews are snug.

ATTACHING SIDEWALLS:

1. The heavy-duty zippers on the sidewalls are "self-lubricating" and although you may find them stiff at first, they will handle much easier with use.

(For orientation when unfolding walls, the roll-up straps are attached along the top edge.)

2. Zip sidewalls to topper, and then zip sidewalls to each other along the legs. If one or more side-wall is omitted - as when you have sides and rear closed and the front open for business - use Velcro wind straps to secure side-walls to legs.

ANCHORING:

Whenever possible, use the Tie-down Screws and Spikes included with the unit. If setting up where neither is usable, we suggest the use of our **Great Weights** (or other weights) to help resist the wind. In windy conditions, we urge you to keep your Vents open to release wind pressure.

SUGGESTIONS FOR PACKING UP:

Release wind straps, remove Sidewalls, fold carefully, and store in short **Carry Bag**.

Remove StaBar poles. Loosen thumbscrews at tops of rear legs and remove legs. From inside (with the canopy standing on 2 legs), release all buckle straps - pinch buckles on their sides. Release the velcro strip along the front upper pole.

Loosen thumbscrews and remove front legs.

Remove Topper by folding from back to front: First fold back edge to center top of arches. Next fold a second time towards the front. Roll from right to left. Store in long **Carrying Bag**.

Remove arches as follows:

Remove Bolts from center arches.

For ease in separating arches, remove the arches at the arch bases first. Using your toe on the front purple pole, simply pull the arch off the Rafter Bases and Corners. Arch sections will now disconnect easily. Store in **Pole Bags** or bundle with ball bungees.

Vinyl is a tough, durable fabric. It resists mildew and dirt but should receive your care and attention. Do not store wet. If you've had to break down wet, allow canopy to dry when you get home.

Dirt can be removed with any regular non-abrasive liquid household cleaner. Use Windex on clear-walls.